

Effective High Shear Technology

The Dynashear features a first-in-class tandem shear head design. It combines the benefits of both an axial and a radial stage, creating excellent shear and flow characteristics. The result is droplet size reduction as low as 2 - 3 microns and a very narrow distribution, plus flow capacities that are substantially higher than existing inline mixers.



The Dynashear Makes Your Job Easier and Faster!

- Easy to operate
- Mixing is completed in minutes
- Designed for rapid cleanability and changeovers
- Easy to disassemble and reassemble
- Low maintenance design
- Minimum downtime – no bushings, wear sleeves, shims or bearing supports to wear out
- Technology designed for 24/7 operation

Specification Highlights:

- Seal pressure ratings up to up to 31 bar at 204 °C, model dependent
- Balanced single and double-barrier mechanical seals designed for durability under extreme operating conditions. Lab model has single seal only.
- Processes from 1 - 1325 liters per minute, model dependent
- VFD standard on lab model



VFD interface

DS-215
lab scale model

The DS-215 is designed for product development, simulation, and scale up. Predictable, repeatable results from lab to full production!



Create Better Emulsions for:

Paints, Inks, Coatings
Lubricants
Adhesives
Agricultural Products

Improves Your Process

The Dynashear is designed to provide maximum versatility to meet your processing needs, and is offered in several different configurations. Whether you are looking for a stand alone inline mixer, a mixer to augment your batch process agitator, or further product refinement, our Dynashear models ensure consistent quality with precise reproducibility.

Sizing and Engineering Data

CX Model	Axial Diameter (mm)	Axial Tip Speed (m/s)	Radial Dia. (mm)	Radial Tip Speed (m/s)	Motor Size (kW)	Motor Speed (rpm)	Flow Rate Ranges (l/min)	Seal Pressure Rating
DS-215	31.75	11.5	54.1	19.5	1.5	6900	8 - 83	10 bar at 93 °C
DS-425	57.15	10.6	107.9	20.4	4	3600	76 - 303	31 bar at 204 °C
DS-575	92.96	17.6	146.05	27.4	15	3600	189 - 606	31 bar at 204 °C
DS-850	142.7	13.4	215.9	20.1	30	1800	454 - 1325	31 bar at 204 °C

Note: Flow rates based on 1 centipoise. High viscosity liquids, solids concentrations, or discharge head conditions may require an auxiliary feed or booster pump.

Dimensions

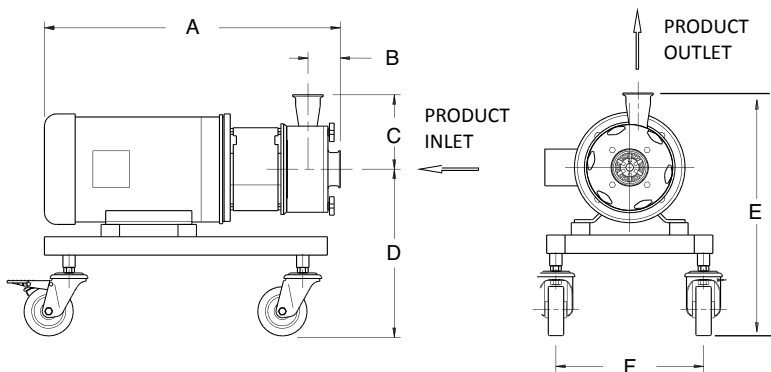

Model	Dimensions (mm)						Sanitary Fitting Size	
	A	B	C	D	E	F	Inlet	Outlet
DS-215	422	46	104	348	452	305	1.5"	1"
DS-425	635	66	155	333	488	305	2.5"	2"
DS-575	787	79	236	379	615	406	4"	3"
DS-850	1105	173	193	505	698	559	6"	4"

Note: Dimensions are approximate and subject to change.
DS-215 comes standard on a mobile cart. Overall dimensions = 711 mm length, 457 mm width, 991 mm height.

Advanced Dual Stage Design

The Primary Axial Stage

An axial flow rotor feeds into a stator with multiple small ports, forcing material between their faces and out through the ports. This mechanical and hydraulic action causes tremendous shearing action and "pre-mixes" the materials prior to entering the secondary stage. Particle and droplet size reduction down to 5 - 7 microns is typical in this stage.



The Secondary Radial Stage



A radial, high flow rotor discharging through a slotted stator provides additional mechanical and hydraulic shear. The centrifugal force at this stage allows the mixture to be pushed away from the shaft and along the radius of the stator, forcing high speed expulsion at the edge of the slots.

This stage provides a substantial momentum change in the flow, resulting in beneficial residence time for further refining of the mixture. Stable emulsions with droplet sizes of 2 - 3 microns or less are typical within this stage.

The Benefits of Advanced Mechanical Design

This unique design makes the Dynashear much more effective at deagglomerating without damaging the particle.

