

Powder Induction and Dispersion System

Admix introduces the latest technology in high performance ergonomic feeding and dispersion of dry ingredients into marinade and brine preparation tanks.

The Fastfeed is an integrated, skid mounted inline powder induction and dispersion system using a specially designed powder suction pump and proven high shear mixing technology for rapid incorporation and wetting out of difficult powders.

Process Features & Benefits

- Optimum powder feed rates up to 160 lbs/min
- Insure full functionality of ingredients
- Reduce minimum batch size
- Easily handle higher viscosity marinades
- Reduce foaming and air entrainment
- Optional wand for easy liquid additions
- Safely dump powders from floor level
- Eliminate wasted brine and ingredients
- Reduce mixer maintenance
- Increase yields especially on injected products
- Eliminate "bath tub ring" in mix tanks
- Shorter mix times
- Eliminate in-tank high shear mixers
- Supply multiple tanks with one unit



An Overview of How the Fastfeed Works

Built on a portable worktable, the Fastfeed system encompasses a hopper, our self-priming liquid ring pump, our high shear inline mixer/emulsifier called the Dynashear[®], a vacuum gauge and various valves and controls. The system operates on the simple principles of vacuum and high shear. The Fastfeed connects to your liquid source or recirculation tank. Using the built-in waist-height worktable, the operator pours ingredients into the hopper. Once the operator has flooded and energized the system, powder induction begins. Powder is pulled in through the liquid ring pump at speeds up to 500 lbs./minute depending on model configuration and powder type, and then passes through the Dynashear[®] resulting in instantaneous fluidization and shearing. Slurries with droplet and soft particle size reduction down to 4-5 microns are provided upon exiting the unit.

The Fastfeed Powder Induction & Dispersion System

The Fastfeed is unlike any other powder induction system, which typically relies on an educator, venturi, or negative pressure generated by a high-speed mix head. The Fastfeed uses a high performance powder suction pump that vacuum conveys from 5 to over 150 lbs/min of any powder, including hard to handle soy proteins, starches, phosphates, spices and powdered broth.

The design of the Fastfeed allows for continuous powder suction even as the viscosity and solids level increase... insuring that the system will never plug or foul.

For the meat and poultry processor, we have developed a unit to provide accurate, fixed powder feed rates and require no adjustments by the operator. Its design is easy-to-use and insures that the proper concentration of dry materials are added quickly and effectively. Complete 100% dispersion of powders is guaranteed as the powder slurry mixture is passed through the high speed DynaShear inline high shear mixer, where most formulas are finished in less than 5-minutes of re-circulation [after all ingredients are added]. This insures full functionality of ingredients and consistently high yields.

The table below illustrates typical powder feed rates of our Fastfeed.

Performance Table for Fastfeed FF-425R

Examples of Typical Ingredient Type	Maximum Powder Feed Rate (# per min)
Phosphates	140 - 160#
Salt	80 - 100#
Soy Protein	40 - 60#
Modified starch	30 - 60#
Carrageenan	30 - 40#
Broth	60 - 80#
Spice	40 - 110#

Model	Pump	Mixer	Hopper	Skid Fittings
FF-425R	7.5 HP @ 1800 rpm	5 HP @ 3600 rpm	3.4 cubic ft	2" Ø TriClamp inlet 2" Ø TriClamp outlet

TriClamp® is a registered trademark of Tri-Clover/Alfa Laval

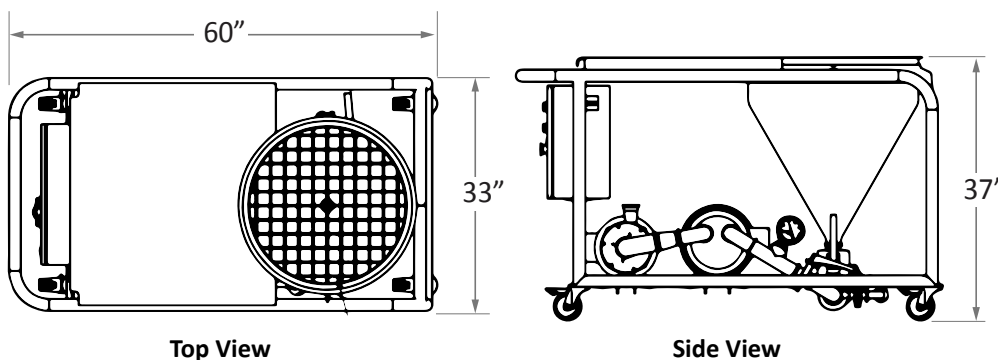

Advanced Powder Induction and Dispersion

How and Why it Works

The Fastfeed combines the suction capability of a "vacuum pump", with the wetting out and shearing capabilities of a high speed, inline high shear mixer, all within an easy-to-use ergonomic package. Powder is fed into the hopper from bags as shown on the cover.

Powder bridging or rat holing is eliminated by the combination of the suction pump creating a constant vacuum within the flow stream, aided by a mechanical vibrator for the more challenging ingredients.

Once powder is sucked in through the pump, instantaneous shearing and fluidization of the powder begins, and this slurry is quickly pumped through our DynaShear inline high shear mixer providing droplet and soft particle size reduction down to 4 to 5 microns upon exiting the unit.

Powder feed rate is controlled with factory settings, insuring controlled, but rapid, dispersion and at the proper concentrations to prevent product slugs or premature hydration.

While many ingredients can be 100% dispersed with one pass, the Fastfeed pump and skid should be configured on a recirculation loop for multiple passes through the DynaShear. A single Fastfeed skid can also be used to feed multiple tanks.

Mechanical Features

- All contact surfaces are 316L with welds blended & polished
- NEMA 4X control panel
- Optional wand for liquid additions
- Minimized piping and connections for quick disassembly & reassembly

See it in action at
www.admix.com/fastfeed



Admix, Inc.
144 Harvey Rd.
Londonderry NH 03053
800-466-2369 / 603-627-2340
www.admix.com

Admix Europe ApS
Praestemosevej 2-4
3480 Fredensborg, Denmark
+45 3213 8743
www.admix.dk

EMPLOYEE OWNED...
CUSTOMER FOCUSED