

All-in-One system that simultaneously induces and disperses powders.

The Fastfeed product line is the ideal solution for high performance ergonomic feeding and dispersion of powder ingredients into mix tanks or directly inline. Integral to the system is a specially designed liquid ring pump and high shear mixer to ensure rapid incorporation and wetting out of difficult powders.

Mechanical Features

- All contact surfaces are 316L with welds blended and polished
- NEMA 4X control panel
- PLC automation options
- Explosion proof motor and components available
- Optional double mechanical seal for abrasive applications
- Optional wand for liquid additions

Ergonomic Design

Powder is fed into the hopper from bags at waist-height via the worktable or can be directly conveyed from the source through our optional wand attachment. Using your bag dump station or bulk delivery system are also possible.

An Overview of How the Fastfeed Works

Built on a portable worktable, the Fastfeed system encompasses a hopper, our self-priming liquid ring pump, our high shear inline mixer/emulsifier called the Dynashear®, a vacuum gauge and various valves and controls. The system operates on the simple principles of vacuum and high shear. The Fastfeed connects to your liquid source or recirculation tank. Using the built-in waist-height worktable, the operator pours ingredients into the hopper. Once the operator has flooded and energized the system, powder induction begins. Powder is pulled in through the liquid ring pump at speeds up to 500 lbs./minute depending on model configuration and powder type, and then passes through the Dynashear® resulting in instantaneous fluidization and shearing. Slurries with droplet and soft particle size reduction down to 4-5 microns are provided upon exiting the unit.



Uniform, Effective Flow of Powder

Traditional powder flow problems such as bridging or rat-holing are minimized by the combination of the Liquid Ring Pump creating a constant vacuum within the flow stream, aided by a mechanical vibrator for more challenging ingredients. Powder suction is continuous even as viscosity and solids level increase, protecting the system against plugging. Powder feed rates are easily adjustable through regulating valves that can be automated to ensure that the proper concentration of dry materials are added quickly and effectively.

Complete 100% Dispersion of Powders

Ingredients are 100% dispersed as the powder slurry mixture passes through the integrated high speed, high-shear Dynashear® mixer, where many applications are finished with just one pass through. With the Fastfeed system, a perfect blend of fully functional ingredients is created in just minutes. If desired, the Fastfeed can be configured on a recirculation loop for multiple passes through the Dynashear®. A single Fastfeed can also be used to feed multiple tanks.

The table below illustrates typical powder feed rates for our Fastfeed systems.

Performance Table for Fastfeed

Ingredient	Powder Feed Rates (lb/minute)		Typical Max. Concentration
	FF-425	FF-575	
Granulated (sugar/salt/phosphates)	200	400	70%
Dairy Powders (skim milk powder)	200	300	52%
Cocoa	90	135	35%
Soy	75	160	10%
Cook Starches	110	165	45%
Natural Gums (i.e. pectin)	30	60	6%
Carbomers	15	30	3.5%
Xanthan	15	30	3%

Model	Pump	Mixer	Hopper	Skid Fittings
FF-425	7.5 HP at 1800 rpm	7.5 HP at 3600 rpm	3.4 cubic ft	2" Tri-Clamp inlet 2" Tri-Clamp outlet
FF-575	15 HP at 1800 rpm	20 HP at 3600 rpm	3.4 cubic ft	2.5" Tri-Clamp inlet 3" Tri-Clamp outlet

Tri-Clamp® is a registered trademark of Tri-Clover\Alfa Laval

Model	A	B	C
FF-425	60"	33"	37"
FF-575	71"	45"	38"

Dimensions are in inches

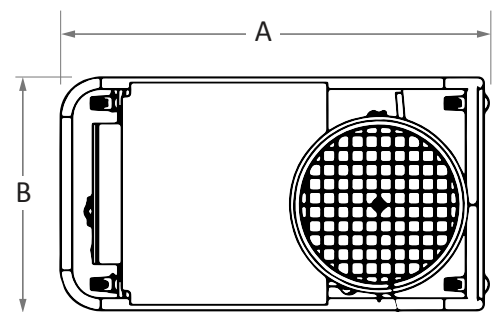
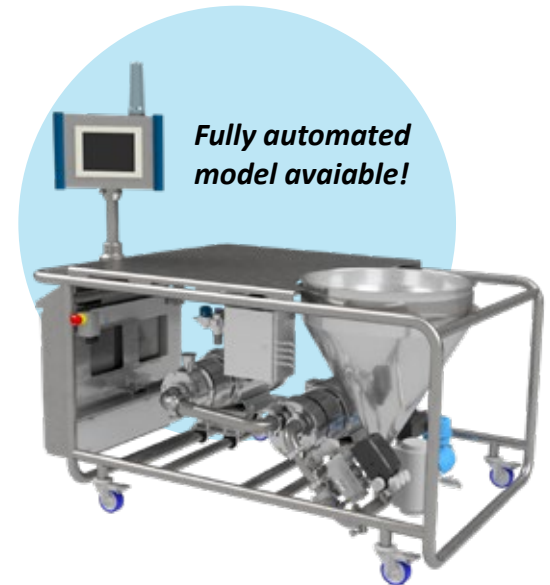

Top View

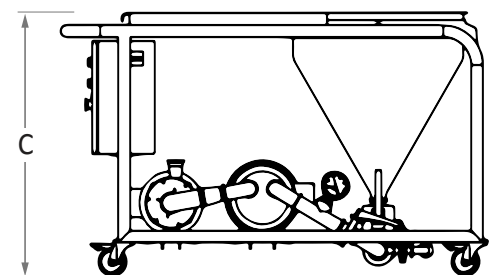

Side View