

Technology designed for 24/7 operation

The Dynashear represents the latest technology for high shear, inline continuous processing, or batch processing with recirculation. The Dynashear will mix, dissolve, deagglomerate, disperse, and emulsify a wide range of fluids and semifluids, and is particularly effective for wetting out powders into a liquid. It features a first-in-class tandem head design combining the benefits of both an axial and a radial stage, creating excellent shear and flow characteristics.



Production size models shown: **DS-425, DS-850**

New DS-850 model allows for greater throughput!



VFD interface

DS-215
lab scale model

The DS-215 is designed for product development, simulation, and scale up. Predictable, repeatable results from lab to full production!



The Dynashear advantages – making your job easier and faster!

- Total washdown and CIP capability conforming to 3-A Sanitary Standard **#36-01**
- EHEDG Certified TYPE EL Class 1 hygienic design available on request (DS-425 and DS-575 models only).
- Low maintenance design for minimum downtime – no bushings, wear sleeves, shims or bearing supports to wear out
- Disassemble and reassemble for inspection and cleaning in approximately five minutes
- Processes from 1 - 1325 liters per minute, model dependent
- Seal pressure ratings up to 31 bar at 204 °C, model dependent
- Choice of single or double-barrier mechanical seals for applications with CIP requirements. Lab model offered with single seal only.
- VFD standard on lab model



Improves Your Process

The Dynashear is designed to provide maximum versatility to meet your processing needs, and is offered in several different configurations. Whether you are looking for a stand alone inline mixer, a mixer to augment your batch process agitator, or further product refinement, our Dynashear models ensure consistent quality with precise reproducibility.

Sizing and Engineering Data

Model	Axial Diameter (mm)	Axial Tip Speed (m/s)	Radial Diameter (mm)	Radial Tip Speed (m/s)	Motor Size (kW)	Motor Speed (rpm)	Flow Rate Ranges (l/min)	Seal Pressure Rating
DS-215	31.75	11.5	54.1	19.5	1.5	6900	8 - 83	10 bar at 93 °C
DS-425	57.15	10.6	107.9	20.4	4	3600	76 - 303	31 bar at 204 °C
DS-575	92.96	17.6	146.05	27.4	15	3600	189 - 606	31 bar at 204 °C
DS-850	142.7	13.4	215.9	20.1	30	1800	454 - 1325	31 bar at 204 °C

Note: Flow rates based on 1 centipoise. High viscosity liquids, solids concentrations, or discharge head conditions may require an auxiliary feed or booster pump.

Dimensions

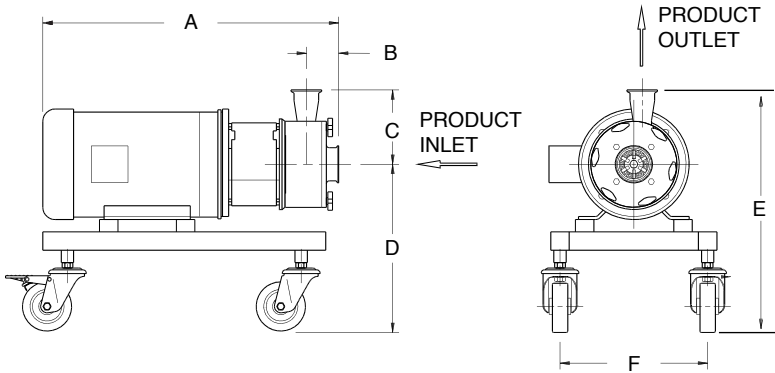

Model	Dimensions (mm)						Tri-Clamp® Fitting	
	A	B	C	D	E	F	Inlet	Outlet
DS-215	422	46	104	348	452	305	1.5"	1"
DS-425	635	66	155	333	488	305	2.5"	2"
DS-575	787	79	236	379	615	406	4"	3"
DS-850	1105	173	193	505	698	559	6"	4"

Note: Dimensions are approximate and subject to change.

DS-215 comes standard on a mobile cart. Overall dimensions = 711 mm length, 457 mm width, 991 mm height.

Advanced Dual Stage Design

The Primary Axial Stage

An axial flow rotor feeds into a stator with multiple small ports, forcing material between their faces and out through the ports. This mechanical and hydraulic action causes tremendous shearing action and "pre-mixes" the materials prior to entering the secondary stage. Particle and droplet size reduction down to 5 - 7 microns is typical in this stage.



The Secondary Radial Stage



A radial, high flow rotor discharging through a slotted stator provides additional mechanical and hydraulic shear. The centrifugal force at this stage allows the mixture to be pushed away from the shaft and along the radius of the stator, forcing high speed expulsion at the edge of the slots.

This stage provides a substantial momentum change in the flow, resulting in beneficial residence time for further refining of the mixture. Stable emulsions with droplet sizes of 2 - 3 microns or less are typical within this stage.

The Benefits of Advanced Mechanical Design

This combination provides greater efficiency and effectiveness over conventional inline mixers that offer either all axial or all radial technology only. A single pass through the Dynashear meets product quality typical of multiple passes using conventional mixers.

