

Outperforms inline mixers, conventional shearpumps and colloid mills

The Boston Shearmill is our ultimate machine for providing high to extreme shear rates and tip speeds for maximum droplet and particle size reduction. If your process requires milling of soft particles to under 1 micron, or hard particles down to 1-2 microns, the Boston Shearmill will meet this criteria, often with just a single pass at high production rates! The Boston Shearmill has replaced colloid mills and homogenizers where submicron processing was not necessary. Existing installations include tomato paste enhancement and standardization, ketchup and mustard production, salad dressing and mayonnaise, pet foods and treats, soups and sauces, flavor emulsions, pharmaceutical formulations, polymers and more. Each rotor/stator shear head has a double ring design, resulting in three distinct, high intensity work zones at each shear head location (up to 3) where the mixture passes. Models with three shear heads provide nine high shear work zones to handle your toughest processing needs. This residence time between the stages allows for creating tremendous mechanical and hydraulic energy for applying maximum shear forces into the product.

The best built, heavy duty, all purpose inline milling machine on the market

- Standard shear head grades include coarse, medium, and fine
- Special purpose heads available for texturizing and blending without damaging or altering solids and desired consistency



- Shearmill models available from 5 - 55 kW, providing product throughput from 18 - 625 l/min depending upon feed rate and viscosity
- Features single mechanical quench seal rated for 48 bar, (double seal optional), and complies with 3A (#36-01) standards 

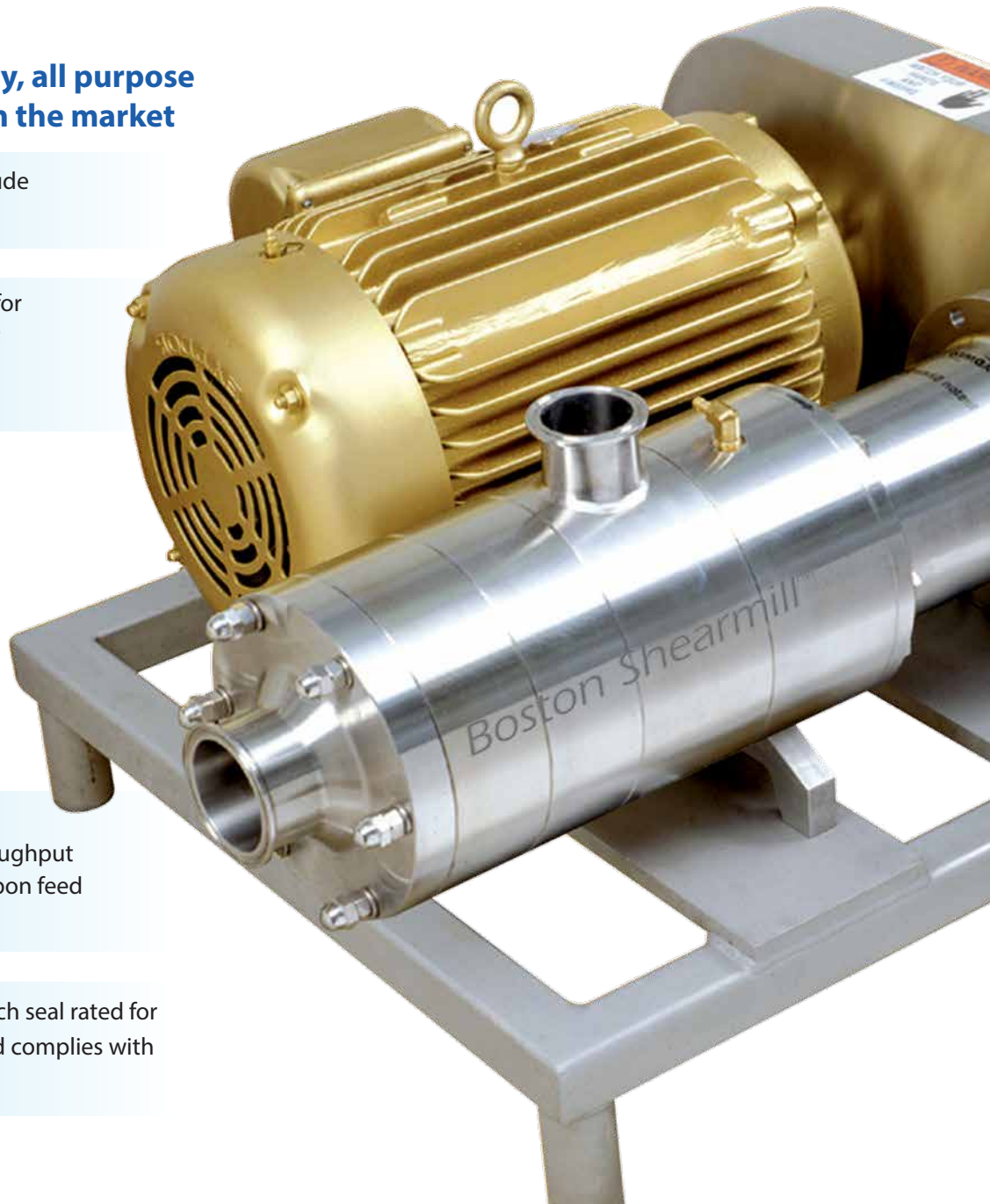

The Boston Shearmill BSM-25, 37 & 60

A wet mill should be judged by how well it does its job, but equally important is that the machine be strong enough to work day after day and year after year, with as little need for service as possible. The Boston Shearmill is designed for 24 / 7 operation, through your most critical processing schedules when downtime is not an option.

The Boston Shearmill combines a well-proven rotor-stator principle with the latest innovations in seal design and bearing support technology. The design is deceptively simple but exceptionally durable. The engineering goal was to create a superior mixer that would outperform all others in its class, so rugged that downtime would be reduced to an absolute minimum.

Standard Models & Specifications

Model	Tip Speed	Throughput	Motor / Speed	Fittings*	Footprint (mm)
BSM 25-3	32.61 MPS	18-56 l/min	15 kW at 10,000 rpm	1.5" In / 1" Out	660x686x534
BSM 37-3	49.07 MPS	56-190 l/min	30 kW at 7,300 rpm	2.5" In / 2" Out	762x762x660
BSM 60-1 & 60-3	33.22 MPS	150-625 l/min	55 kW at 3,600 rpm	3" In / 2" Out	1625x635x686

*Fittings are Tri-Clamp®

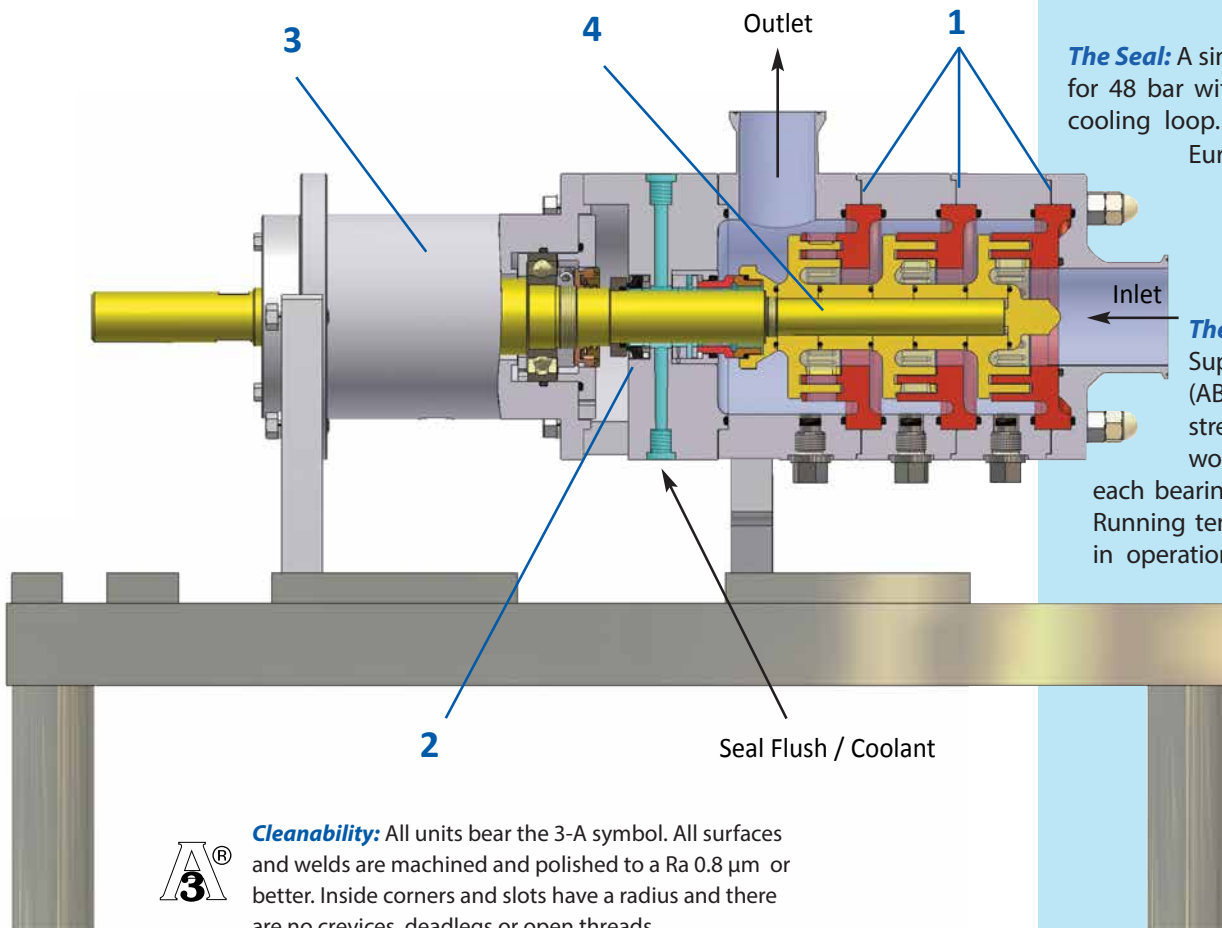

Cleanability: All units bear the 3-A symbol. All surfaces and welds are machined and polished to a Ra 0.8 µm or better. Inside corners and slots have a radius and there are no crevices, deadlegs or open threads.

Design Technology and features

The Manufacturing Process: Rotor and stator ports have wire-cut radii with computer controlled precision. Double thickness housings for the bearing frame and mixer body are built for a lifetime of use. "Cartridge" design on the bearing frame allows quick replacement for servicing. Even our base is twice the strength, weight and rigidity than competitive machines.

1

The Rotor and Stator: Enclosed slot design prevents twisting and bending for maximum durability, longevity and safety. Machined from massive cylinders of AISI 316L or 17-4 SS, and dynamically balanced for smooth rotation through high speeds. Over 20 variations from coarse to ultrafine slots.

2

The Seal: A single mechanical seal rated for 48 bar with a unique low-pressure cooling loop. Complies with U.S. and European hygienic standards.

3

The Bearings: We use only Super Precision Ball Bearings (ABEC 7) with abundant strength for high-speed work. Unique preloading of each bearing protects against spikes. Running temperature is 38° C or less in operation. Protected by labyrinth seals. Complete bearing assembly installs as a cartridge for easy replacement.

4

The Shaft: Oversized, hardened 17-4 Stainless. Stout enough to carry three heads, and perfectly balanced for zero run-out.